



CUNOVA

Service

Continuous Casting &
Rolling Mill Maintenance



SERVICE
DIVISION

The Company	03
Continious Casting Equipment and Rolling Mill Equipment	
Your Full Service Provider for Continious Casting Equipment	04
What makes us unique	05
Continious Casting Maintenance	
Caster Mould	06
Recoating	07
Fiber Optic	08
Mould Frames	09
Foot Rollers + Water Jackets	10
Mould Tubes Refurbishedment	11
Caster Segments	12
Segments Service	13
Rolls Service	14
Specialty Caster Service	15
Rolling Mill Maintenance	
Chocks/Bearings/Sleeves	17
Continious Casting Equipment and Rolling Mill Equipment	
Steel & Engineering	20
Other Service	21
cunova Service Center	
First-Class Service – always close to You	22
Service wherever and whenever You need it	23

The Company

As a pioneer in numerous key areas of industry, cunova offers a wide range of products and solutions that meet the highest standards. From mould tubes and plates to other casting moulds – our products in the field of continuous casting of ferrous and non-ferrous metals set standards worldwide. We are also specialists in extruded and drawn copper products and a high-performance partner for finished components that are developed together with our customers. cunova's expertise also extends to developing highly corrosion-resistant copper-nickel products and coatings that are specially designed for applications in shipbuilding and on offshore platforms in the oil and gas industry. Our portfolio is complemented by our service division, which optimally addresses individual customer needs with advanced services and technical support.

Our corporate philosophy is based on the core value of customer centricity: we are committed to providing our business partners with tailored solutions and superior service exactly where they need it. We have a global network of experts that fosters direct and immediate communication with our customers to understand their specific requirements and guarantee customised results. This collaboration enables us to offer not only efficient products but also complete solutions that deliver real added value and convince in the long term.

Service Division Overview

As a global leader in continuous caster and rolling mill maintenance, we are committed to delivering exceptional quality and expertise to our clients worldwide. With strategically located Service Centers across key regions, including Germany, China, Spain, Turkey, India, the USA, and Mexico, we provide unparalleled global coverage, ensuring prompt and reliable support wherever our clients operate.

Service Division Expertise

Our core expertise lies in the design, manufacturing, and refurbishment of critical components for the steel and metal industries. By offering comprehensive, tailor-made service solutions, we help businesses optimize their operations, improve productivity, and extend the lifespan of their equipment. From precision engineering and advanced diagnostics to proactive maintenance and complete overhauls, our team of industry specialists ensures that our clients achieve maximum operational efficiency and minimize downtime.

Your Full Service Provider

We offer complete refurbishment/design modifications and upgrades for all continuous caster components and rolling mill components from the tundish to the cutting torch. We also provide new components such as moulds, segments, dummy bar chains, conveyor chains, fabrications of all sizes, new copper plates, new roll forgings, oscillator refurbishments, on site equipment installations and equipment alignment.

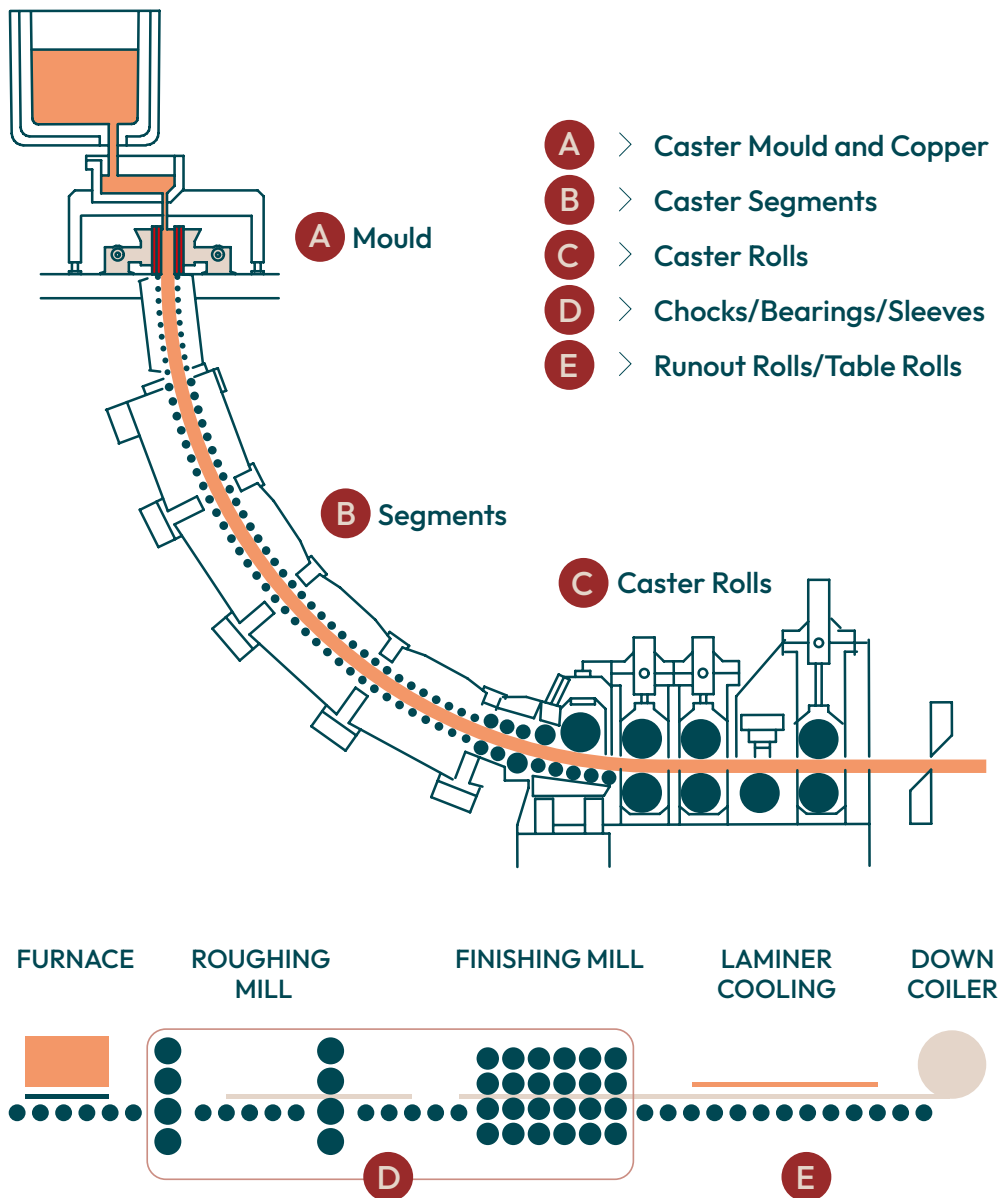

What makes us unique

- **150+ years of expertise:** Proven track record in high-quality copper solutions for steel mills. Customers appreciate our many years of expertise.
- Variety of patents for example in coatings for copper plates
- **Innovative & reliable:** Specializing in new product development and refurbishment of equipment
- **Comprehensive services:** Full portfolio for continuous casting and rolling mill maintenance
- **Rapid onsite support:** Expert troubleshooting services for minimized downtime
- **Engineering excellence:** Huge database of detailed blueprints for precision and customization
- **Custom manufacturing:** Production of new, tailored parts to meet customer
- **Global presence:** Service center network spanning 8 countries for seamless support
- Technical experts as account managers
- Highly skilled and experienced department managers

Caster Mould

We offer complete mould refurbishments, gearbox refurbishment, hydraulic cylinder refurbishment, end wall alignments and rebuilds, frame qualifications, etc. and a variety of patented coatings for broadface and narrowface coppers.

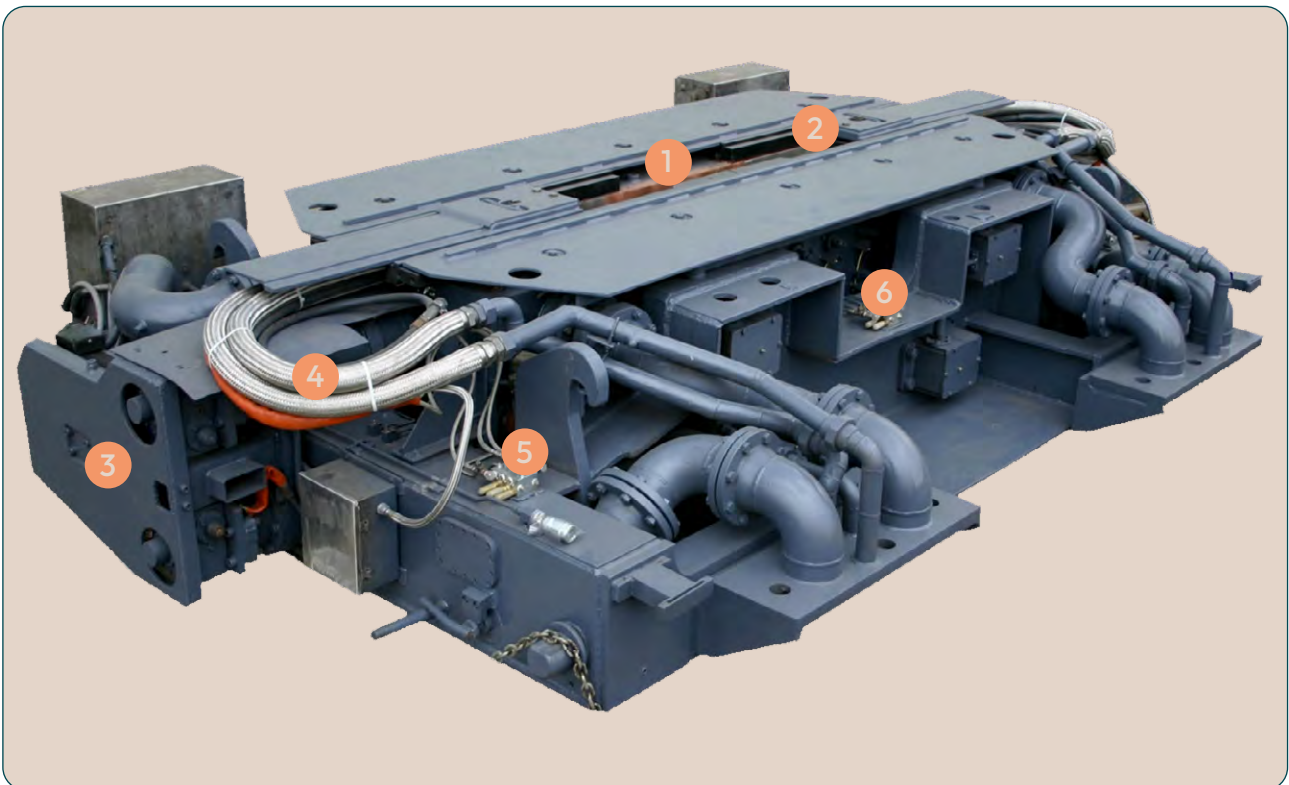

- 1 > Broadface Coppers
- 2 > Narrowface Coppers
- 3 > Gearboxes & Motors
- 4 > Water Cooling & Spray Systems
- 5 > Lubrication Systems
- 6 > Hydraulic Systems

Recoating

- Comprehensive reconditioning/refurbishment of continuous caster mould copper plates
- Refurbishment of mould plates with fibre optic technology
- High-quality nickel & nickel alloy coatings for broad and narrow face plates
- HN20[®], HN40[®], HNK2[®], HWR[®] various galvanic coatings
- HF120[®] and TC1[®] spray coatings offer superior wear resistance
- Edge coatings on adjustable narrow-face plates reduce wear



Fiber Optic

We offer full refurbishments for moulds, which are equipped with FBG-systems, including entrance and exit inspection, disassembly, reassembly and replacement.

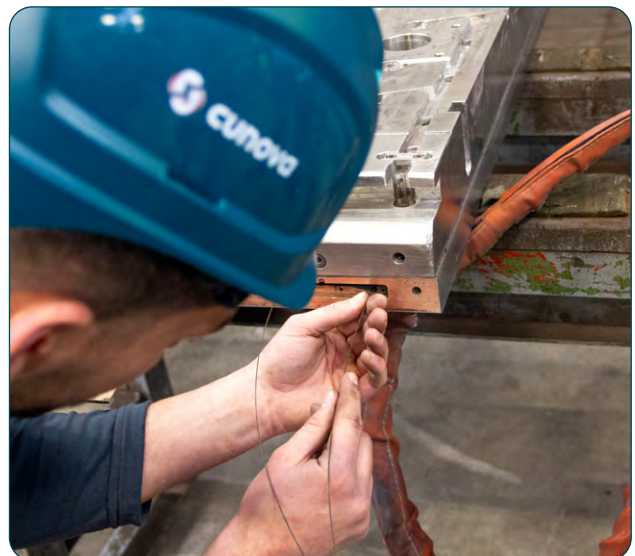
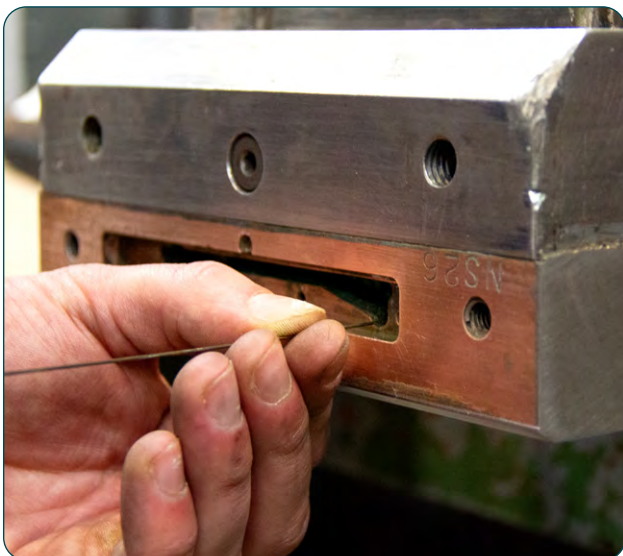
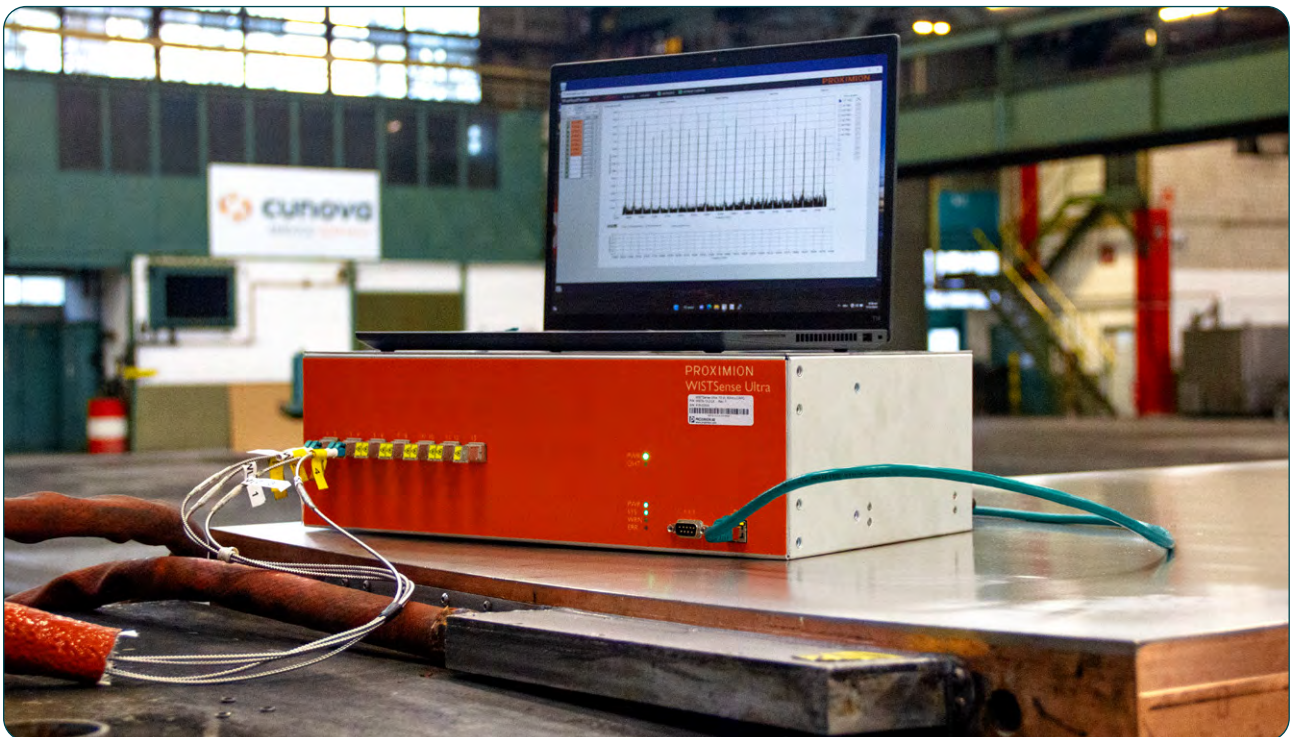

Mould Frames

Extend the life and performance of your slab caster and long product mould frames with our precision refurbishment services, designed to withstand the rigorous demands of steel production.

Our tailored solutions enhance durability, reduce downtime, and ensure consistent casting quality for superior operational efficiency.

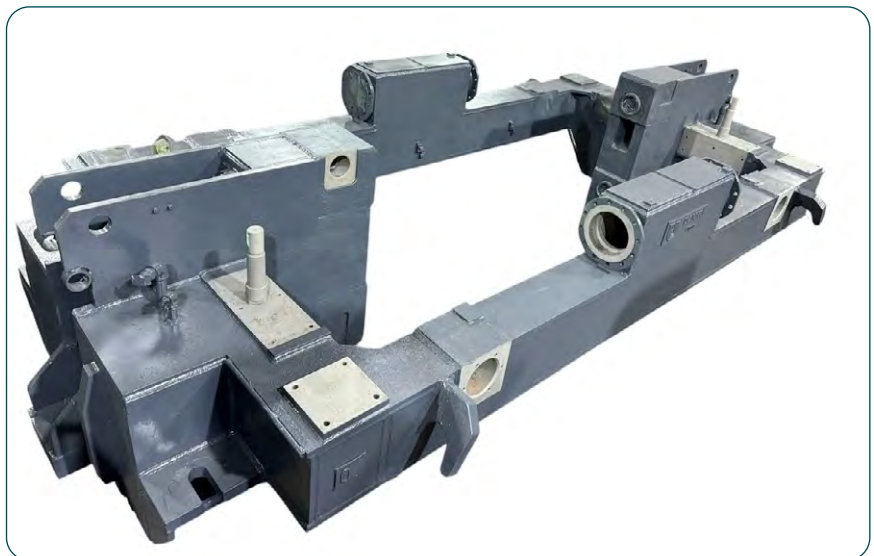
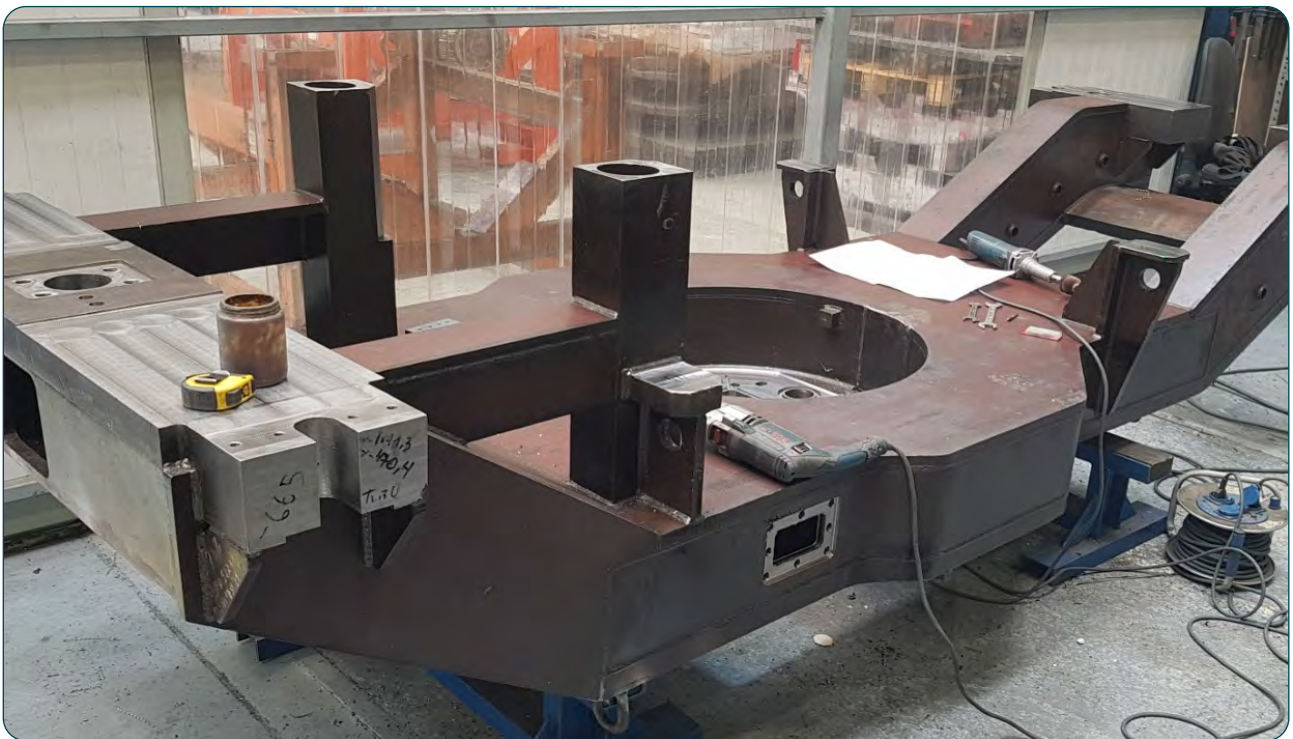

Foot Rollers + Water Jackets

Ensure optimal performance and longevity of your foot rollers and water jackets with our expert maintenance services. Our solutions include precision inspections, wear-resistant refurbishments, and thorough cleaning to maximize cooling efficiency and minimize downtime in steel production.

Foot Rollers



Water Jackets



Mould Tubes Refurbishment

Beam blank mould explosion forming and external copper coating.

Internal copper coating of round and square moulds for billets and blooms.

Chromium coating of finished mould tubes.

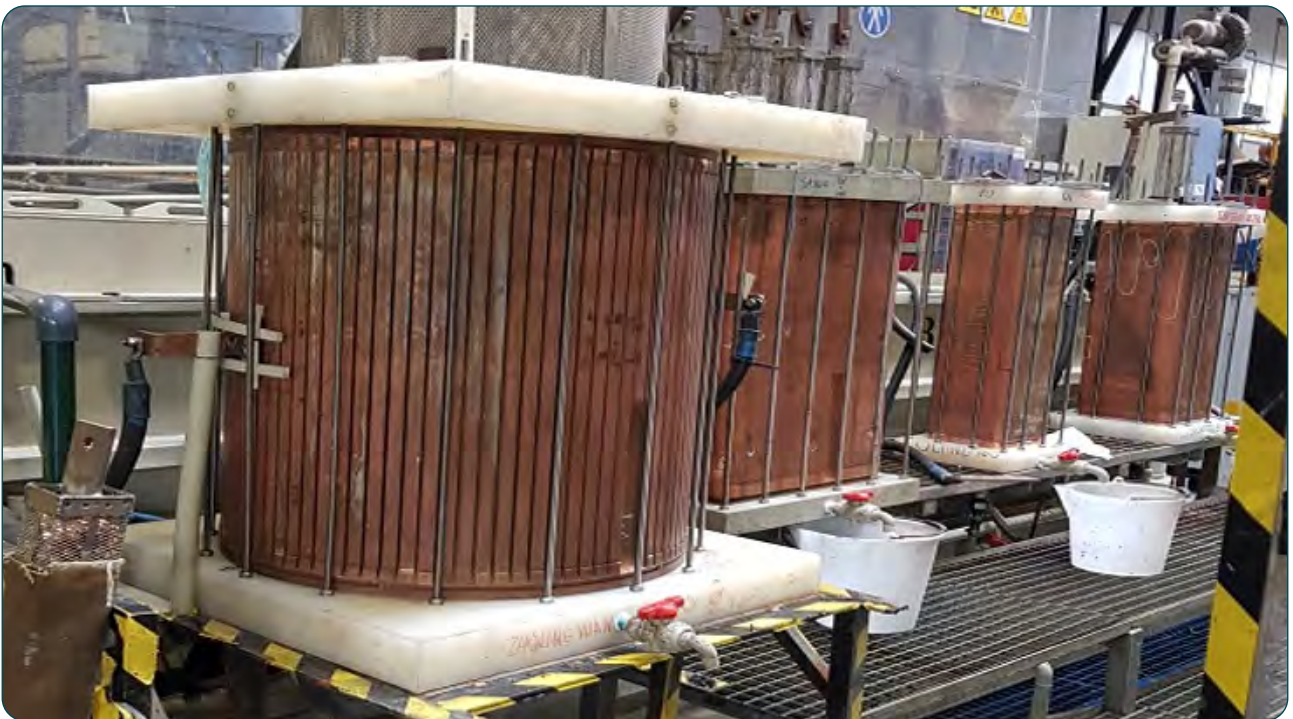

Caster Segments

Complete and conditional based rebuilds, hydraulic system design and installation, grease system replacement and repair, air/oil system design and implementation, roll alignment, frame qualification and repair, new components fabrication, complete roll repair and overlay capabilities, bearing housing replacement and repair, bearing failure analysis, bearing reclamation programs, chemical cleaning of internal water passages.



Slab Caster Segment

- Rollers
- Hydraulic Systems
- Lubrication Systems
- Cooling & Spraying Systems

Segments Service

Used rolls are removed, disassembled, and pre-machined for weld overlay. After pre-heating, they are welded with stainless steel to customer specs, then tempered in stress relief. Finally, the rolls are machined, assembled, and installed into the caster segment.

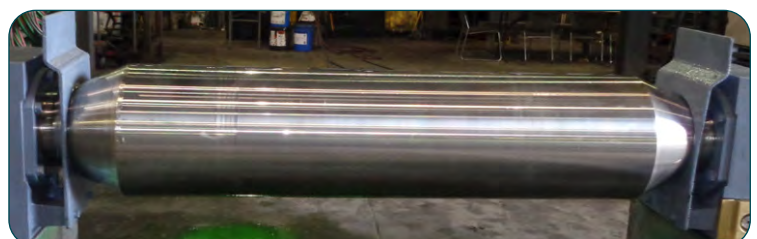
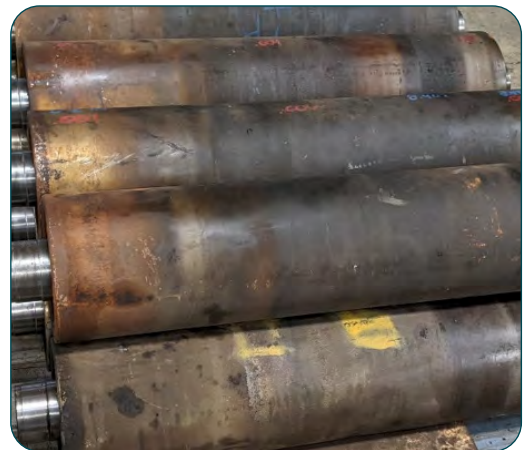

Rolls Service

We offer complete refurbishment of all mill rolls – segment rolls, table rolls, withdrawal rolls, straightener rolls, run out rolls, downcoiler rolls, pinch rolls, descale rolls, etc. All types of rolls are offered new as well.

Before



After

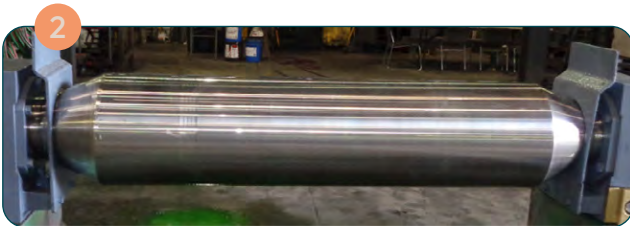
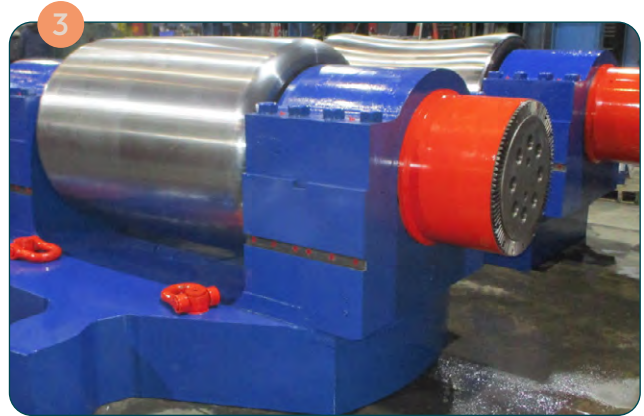

- 1 > Straightener Rolls
- 2 > Withdrawal Rolls

- 3 > IFL Rolls
- 4 > Table Rolls

Specialty Caster Service

We provide services for specialty caster equipment, focusing on the maintenance and refurbishment of all ancillary components essential for efficient casting operations. This includes oscillators, mold tables, dummy bars, tundish cars, and segment support systems.

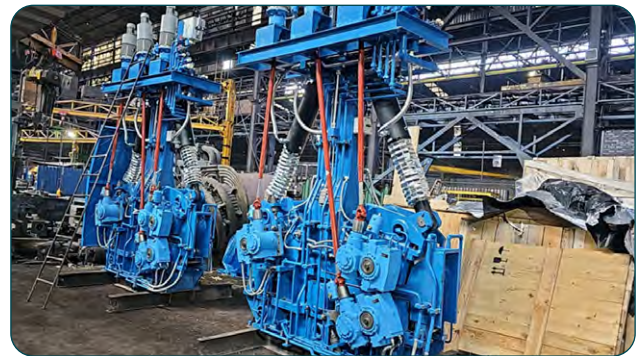



Chocks/Bearings/Sleeves

We offer complete refurbishment of work roll and back-up chocks, babbitt bushings, babbitt sleeves, taper neck sleeves (10” to 80” in diameter), pinion stands, gear drives, grinder blocks, and power industry/power generation bearings.

We are also specialised in rings, inboard/outboard ring spacers, throw rings and gib blocks. Other offerings include high technology coatings, as well as onsite inspections and equipment installations.

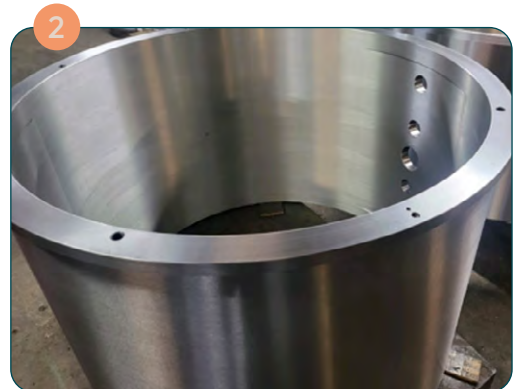

1 > Chock Assembly

2 > Babbitt Bearing

3 > Tapered Sleeve

Chocks/Bearings/Sleeves

- 1 > Bushing machine set up
- 2 > Sleeve spray welding
- 3 > Sleeve surface finishing/control

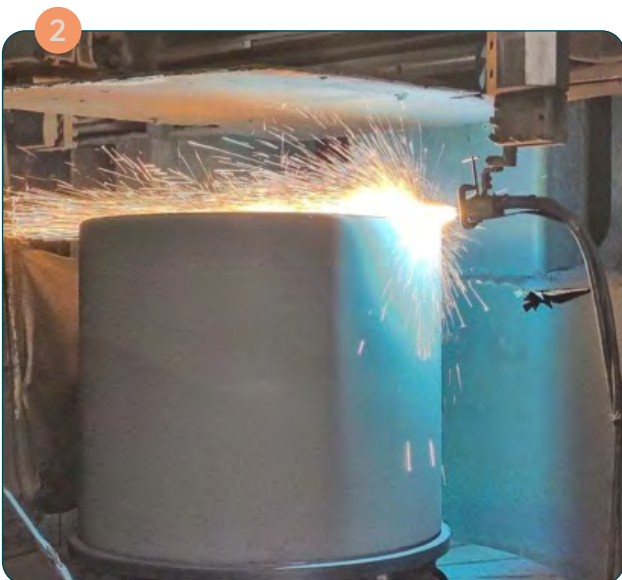

Chocks/Bearings/Sleeves

The refurbishment process includes the comprehensive assessment, repair, and restoration of a work roll chock and a back-up chock, focusing on their condition both before and after operation.

Before



After



Steel & Engineering

- Huge database of detailed drawings of innovative, customized designs
- World leading expertise in critical components like mould coppers
- System modifications to extend lifespan and cut maintenance costs
- State-of-the-art labs for rigorous chemical analysis and non-destructive testing
- Tailored solutions to enhance equipment durability and performance

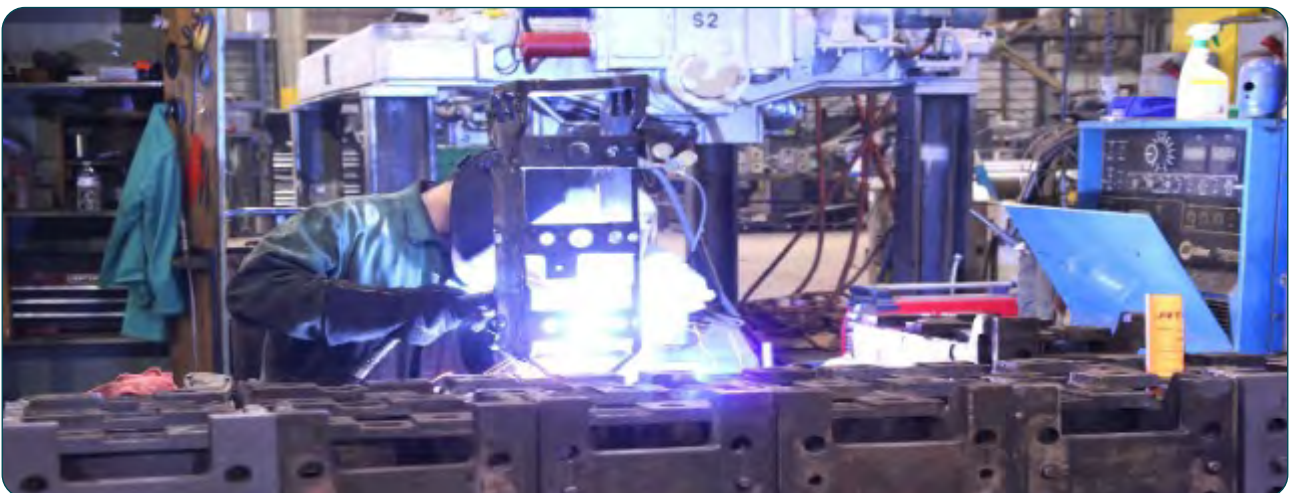

Other Service

We have the equipment, expertise, and personnel to manage every aspect of continuous casting, from onsite visits to refurbishing critical components like oscillators and billet casting equipment, ensuring your operations run efficiently. Beyond steel and casting, we offer precision machining and fabrication services to industries such as mining, plastics, and oil and gas.

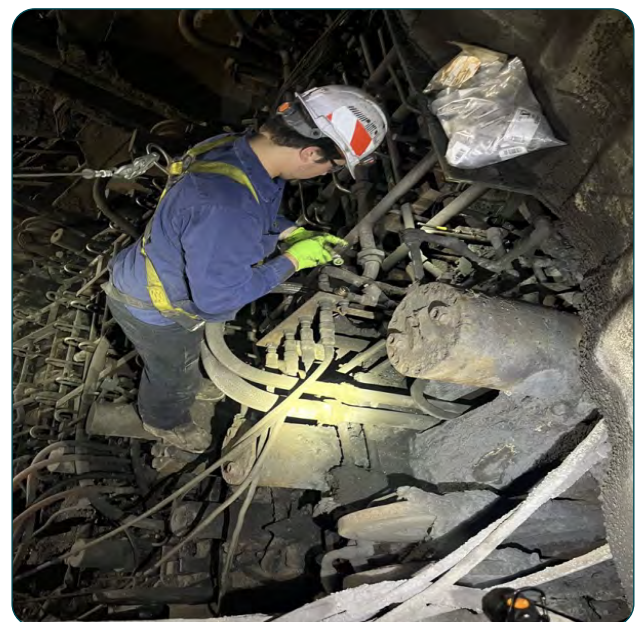

First-class Service – always close to You

Our extensive service network spans multiple global locations, ensuring we are always within reach to support your needs. Each service center is equipped with state-of-the-art technology and staffed by skilled professionals dedicated to delivering top-quality solutions.



CUNOVA SERVICE CHINA



CUNOVA SERVICE GERMANY



CUNOVA SERVICE INDIA



CUNOVA SERVICE MEXICO



CUNOVA SERVICE SPAIN



CUNOVA SERVICE TURKEY



CUNOVA SERVICE USA

Service wherever and whenever You need it



cunova Service Center



cunova GmbH
T: +49 541 321 3400 | M: service.germany@cunova.com



cunova Service USA LLC
T: +1 814 827 7717 | M: sales@cunova.us



M: services@cunova.com



cunova Kalip Servis Sanayi ve Tic. A. Ş.
T: +90 212 244 7460 | M: sales@cunova.com.tr



cunova Service India Pvt. Ltd.
T: +91 804 358 0300 01 | M: sales@cunova.in



cunova Service Mexico S.A. de C.V.
T: +51 818 308 6810 | M: sales@cunova.mx



cunova Service Spain S.A.
T: +34 946 360 128 | M: sales@cunova.es



Further information on Service Capabilities:

cunova GmbH
Klosterstrasse 29
49074 Osnabrück
Germany

services@cunova.com
www.cunova.com

© eingetragenes Warenzeichen

Alle Änderungen vorbehalten. MC0550225.

Aufgrund drucktechnischer Beschränkungen sind die in dieser Broschüre wiedergegebenen Farben als ungefähre Entsprechungen der beschriebenen Farben zu betrachten.